

# Separate Type ABS ST Series

Absolute Scale Unit (High environmental resistance type)

## ABS ST1300 Series

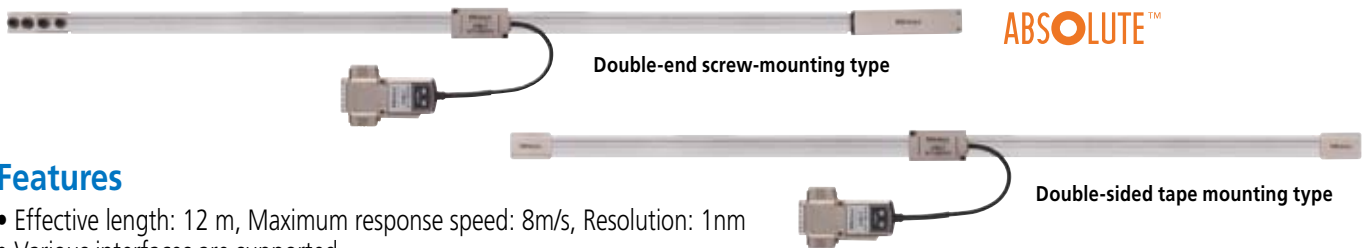

### Features

- Effective length: 12 m, Maximum response speed: 8m/s, Resolution: 1nm
- Various interfaces are supported.
- A new detection method has improved robustness in regards to contamination resistance and gap tolerance (in-house testing result).
- There is a choice of mounting method: double-sided tape or double-end screw.
- Signal check program enables integrity check and maintenance.

### Meaning of Model No.

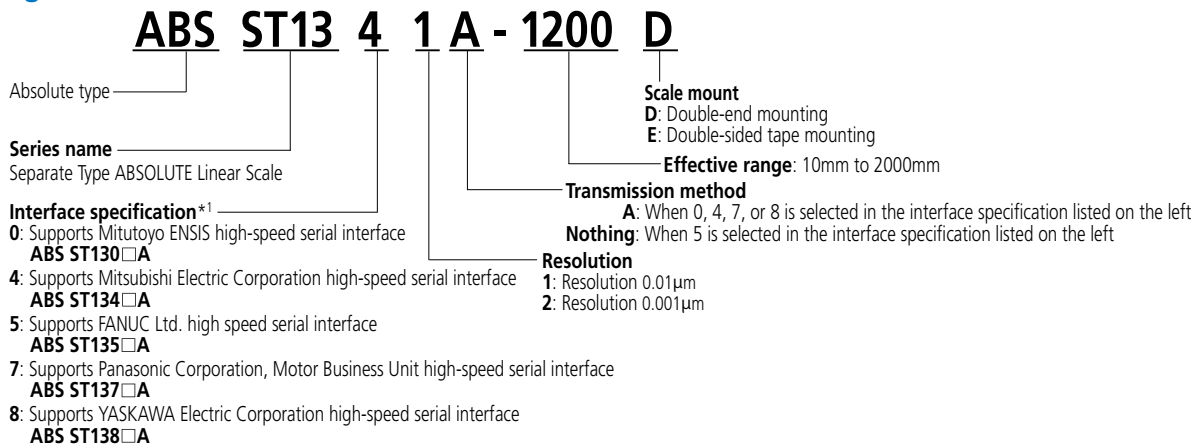

### Available Interfaces

Applicable interfaces*1	Mitutoyo ENSIS*2
	Mitsubishi Electric Corporation, MELSERVO MR-J4 Series
	FANUC Ltd.
	Panasonic Corporation, Motor Business Unit MINAS-A5 Series
	YASKAWA Electric Corporation, Σ-VII Series

\*1 Be sure to contact each manufacturer for details of the applicable systems (availability of connection).

\*2 EENSIS is a registered trademark of Mitutoyo Corporation.

### System Configuration

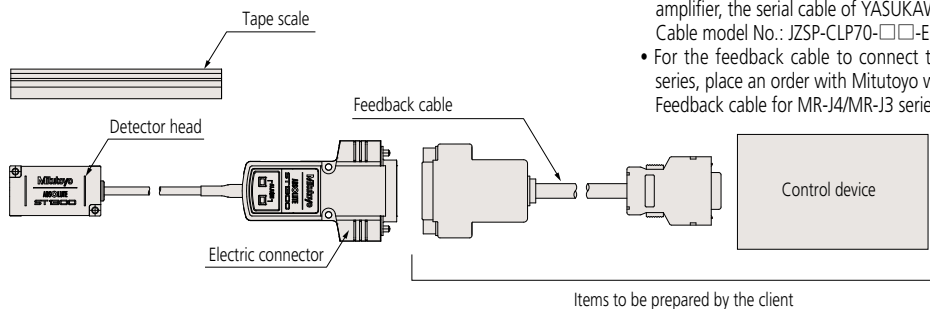

#### ◇ About feedback cable

- For the feedback cable to connect to the YASUKAWA Electric Corporation's servo amplifier, the serial cable of YASUKAWA Electric Corporation is available.  
Cable model No.: JZSP-CLP70-□□-E (03,05,10,15, 20)
- For the feedback cable to connect to Mitsubishi Electric Corporation MR-J4/MR-J3 series, place an order with Mitutoyo with the following order No. specified.  
Feedback cable for MR-J4/MR-J3 series, 5m: No. 06ACF117A, 10m: No.06ACF117B

\* The feedback cable should be prepared by the client.

If the feedback cable of YASUKAWA Electric Corporation is used, the ST1380A connecting cable (optional: **06AFA434A**) is needed.

## Specifications

Item	Model	ABS ST1300	
Detection method		Optical reflection type linear encoder	
Scale type		Metal tape	
		Double-end fixation	Double-stick tape fixation
Maximum effective length		12m	3m
Fixing part material		—	Equivalent to iron
			Other than equivalent to iron
Indication accuracy (20°C)		±5µm (1m or less) ±5µm/m (1.1m or more) *4	±5µm (1m or less) ±5µm/m (1.1m or more)
Resolution		0.001µm/0.01µm (switched at shipment)	
Maximum response speed		8m/s or less	
Applicable Interfaces		Mitutoyo ENSIS, Mitsubishi Electric Corporation I/F, FANUC Ltd. I/F, YASKAWA Electric Corporation I/F, Panasonic Corporation I/F	
Expansion coefficient		≈10x10 <sup>-6</sup> /K *5	≈10x10 <sup>-6</sup> /K *2
GAP allowance		Initial: ±0.1mm Kinetic: ±0.2mm	
Cable length		1m (Highly curved cable)	
Detector size		40 (D) x 22 (W) x 23 (H) mm	
Operation temperature		0 - 50°C	0 - 50°C *1 When mounting: ±10°C
Storage temperature		-20 - 70°C	-20 - 70°C *3

- \*1: Double-sided tape fixing type, careful for the condition of operating temperature range, in case that the sealing surface material is except for Fe equivalent.
- \*2: Thermal expansion coefficient occasionally change, as the difference between scale material's and sealing surface material's is excessive.
- \*3: Double-sided tape fixing type, the accuracy compensation occasionally change, in case that the sealing surface material is except for Fe equivalent and stored in environment over operating temperature range. Imaging these conditions, double-end fixing type is adopted.
- \*4: Tension fix is adopted to be stable the temperature property. Because scale tension is longer 250 µm/m, the accuracy compensation is needed over the system.
- \*5: Thermal expansion coefficient after mounted conform to expansion/contraction of mounted surface by changing outer temperature(Double-end fixing type).

## Relation between resolution for each supported interface, maximum effective length, and maximum response speed

	Resolution	Maximum effective length (mm)		Maximum response speed
		Double-end fixation	Double-stick tape fixation	
Mitutoyo ENSIS	10nm	12000mm	3000mm	8m/s
	1nm	±2100mm *	±1500mm *	8m/s
Mitsubishi Electric Corporation	10nm	12000mm	3000mm	4m/s
	1nm	±2100mm *	±1500mm *	4m/s
FANUC Ltd.	10nm	12000mm	3000mm	8m/s
	1nm	±2100mm *	±1500mm *	8m/s
Panasonic Corporation	10nm	12000mm	3000mm	4m/s
	1nm	±2100mm *	±1500mm *	0.4m/s
YASKAWA Electric Corporation	10nm	12000mm	3000mm	8m/s
	1nm	±1800mm *	±1500mm *	3.6m/s

\* When the center of the effective length is set zero (ORIGIN) at default setting. When zero-set is executed at the edge of the scale, the maximum effective length will change.

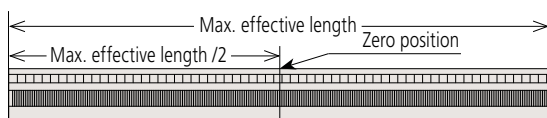

### Effective length

(Double-end fixation): -2100 mm - +2100 mm  
(Mitutoyo ENSIS, Mitsubishi Electric Corporation,  
FANUC Ltd., Panasonic Corporation)  
-1800 mm - +1800 mm  
(Yaskawa Electric Corporation)

(Double-stick tape fixation): -1500 mm - +1500 mm

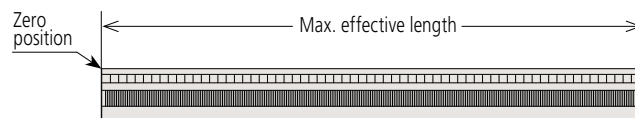

### Effective length

(Double-end fixation/Double-stick tape fixation):  
0 mm - +2100 mm  
(Mitutoyo ENSIS, Mitsubishi Electric Corporation,  
FANUC Ltd., Panasonic Corporation)  
0 mm - +1800 mm  
(Yaskawa Electric Corporation)

## Output specification

Compatible connector  
HDAB-15S  
(Standard accessory)

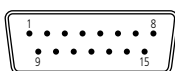

### Pin assignment for Mitsubishi Electric Corporation MELSERVO

Pin No.	Signal	Pin No.	Signal
1, 2	0V (LG)	10	N.C
3, 4	+5V (P5)	11	+5V (P5)
5	N.C	12	N.C
6	N.C	13	0V (LG)
7	MR (RQ/DT)	14	N.C
8	MRR (RQ/DT)	15	F.G
9	N.C	Connector shell	F.G

### Pin assignment for Panasonic Corporation MINAS

Pin No.	Signal	Pin No.	Signal
1, 2	GND	10	N.C
3, 4	+5V	11	+5V
5	N.C	12	N.C
6	N.C	13	GND
7	+REQ/+SD	14	N.C
8	-REQ/-SD	15	F.G
9	N.C	Connector shell	F.G

### Pin assignment for FANUC Ltd. a/a i

Pin No.	Signal	Pin No.	Signal
1, 2	GND	10	N.C
3, 4	+5V	11	+5V
5	SD or SD/REQ	12	N.C
6	_SD or _SD/_REQ	13	GND
7*	REQ or TEST	14	N.C
8*	_REQ or _TEST	15	F.G
9	N.C	Connector shell	F.G

\* TEST/\_TEST signal: Used as a communication line when checking signal.

### Pin assignment for YASKAWA Electric Corporation Σ Series

Pin No.	Signal	Pin No.	Signal
1, 2	GND	10	N.C
3, 4	VCC	11	VCC
5	N.C	12	N.C
6	N.C	13	GND
7	S	14	N.C
8	/S	15	F.G
9	N.C	Connector shell	F.G

## External View

- Double-end fixation type (Effective length: 500 to 1000mm)

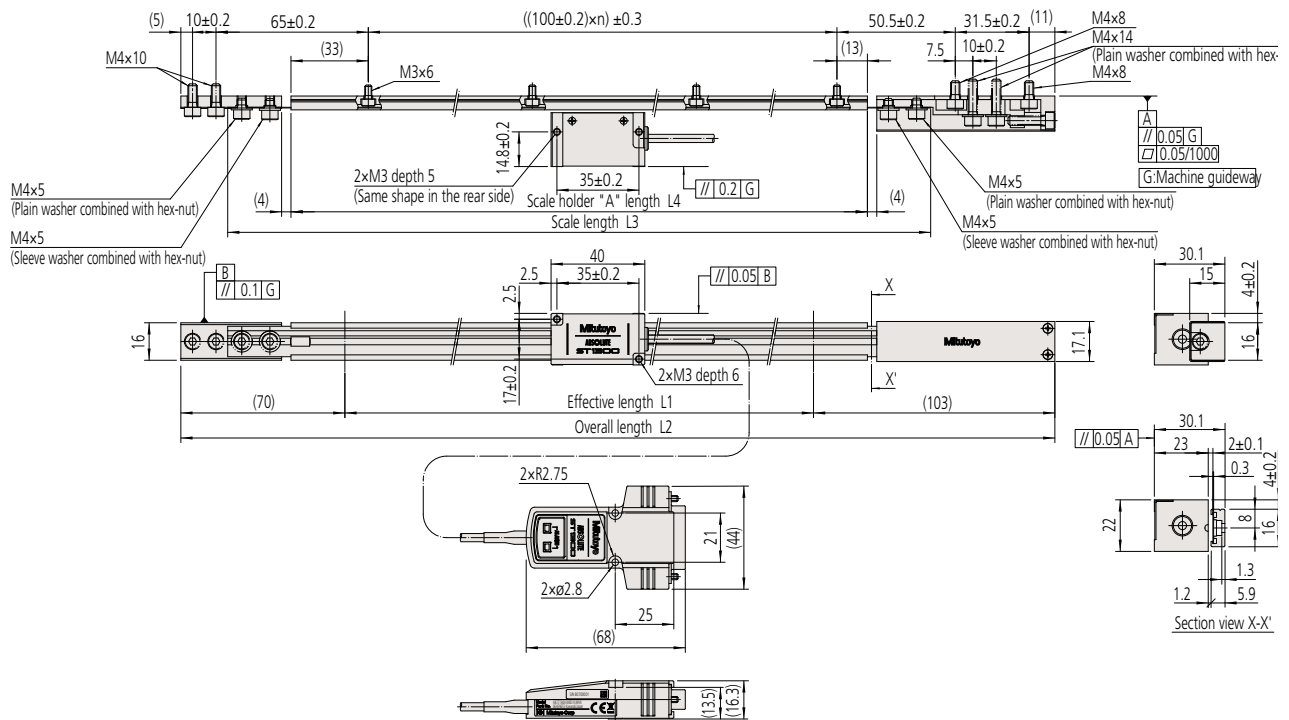

## Dimensions

- Resolution: 0.01µm

Order No.	Code	Effective length L1 (mm)	Scale length L2 (mm)	Scale length L3 (mm)	Scale holder A L4 (mm)	No. of mounting holes	Mass (g)
579-434-□1	ST13◇1A-00500D	500	673	600	546	5	513
579-435-□1	ST13◇1A-00600D	600	773	700	646	6	534
579-436-□1	ST13◇1A-00700D	700	873	800	746	7	556
579-437-□1	ST13◇1A-00800D	800	973	900	846	8	578
579-438-□1	ST13◇1A-00900D	900	1073	1000	946	9	599
579-439-□1	ST13◇1A-01000D	1000	1173	1100	1046	10	621

## Dimensions

- Resolution: 0.001µm

Order No.	Code	Effective length L1 (mm)	Scale length L2 (mm)	Scale length L3 (mm)	Scale holder A L4 (mm)	No. of mounting holes	Mass (g)
579-434-□2	ST13◇2A-00500D	500	673	600	546	5	513
579-435-□2	ST13◇2A-00600D	600	773	700	646	6	534
579-436-□2	ST13◇2A-00700D	700	873	800	746	7	556
579-437-□2	ST13◇2A-00800D	800	973	900	846	8	578
579-438-□2	ST13◇2A-00900D	900	1073	1000	946	9	599
579-439-□2	ST13◇2A-01000D	1000	1173	1100	1046	10	621

□ indicates the interface specification (0,4,5,7,8).

◇ indicates the interface specification (0,4,5,7,8).

## External View

- Double-end fixation type (Effective length: 1100 to 12000mm)

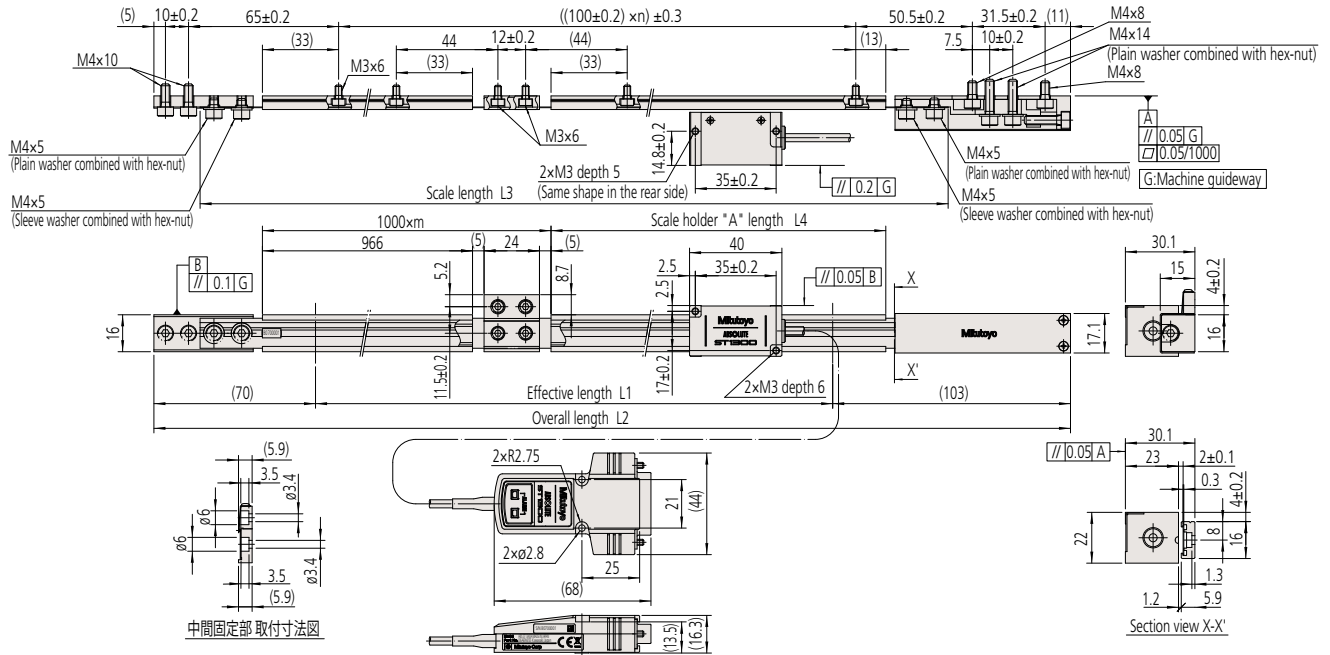

## Dimensions

- Resolution: 0.01μm

Order No.	Code	Effective length L1 (mm)	Scale length L2 (mm)	Scale length L3 (mm)	Scale holder A L4 (mm)	No. of mounting holes	Mass (g)
579-440-1	ST13◇1A-01100D	1100	1273	1200	146	11	659
579-441-1	ST13◇1A-01200D	1200	1373	1300	246	12	680
579-442-1	ST13◇1A-01300D	1300	1473	1400	346	13	702
579-443-1	ST13◇1A-01400D	1400	1573	1500	446	14	724
579-444-1	ST13◇1A-01500D	1500	1673	1600	546	15	745
579-445-1	ST13◇1A-01600D	1600	1773	1700	646	16	767
579-446-1	ST13◇1A-01700D	1700	1873	1800	746	17	788
579-447-1	ST13◇1A-01800D	1800	1973	1900	846	18	810
579-448-1	ST13◇1A-02000D	2000	2173	2100	1046	20	853
579-449-1	ST13◇1A-02200D	2200	2373	2300	246	22	913
579-450-1	ST13◇1A-02400D	2400	2573	2500	446	24	956
579-451-1	ST13◇1A-02500D	2500	2673	2600	546	25	977
579-452-1	ST13◇1A-02600D	2600	2773	2700	646	26	999
579-453-1	ST13◇1A-02800D	2800	2973	2800	846	28	1042
579-454-1	ST13◇1A-03000D	3000	3173	3100	1046	30	1085
579-455-1	ST13◇1A-03200D	3200	3373	3300	246	32	1145
579-456-1	ST13◇1A-03400D	3400	3573	3500	446	34	1188
579-457-1	ST13◇1A-03600D	3600	3773	3700	646	36	1231
579-458-1	ST13◇1A-03800D	3800	3973	3900	846	38	1274
579-459-1	ST13◇1A-04000D	4000	4173	4100	1046	40	1318
579-460-1	ST13◇1A-04200D	4200	4373	4300	246	42	1377
579-461-1	ST13◇1A-04400D	4400	4573	4500	446	44	1420
579-462-1	ST13◇1A-04600D	4600	4773	4700	646	46	1463
579-463-1	ST13◇1A-04800D	4800	4973	4900	846	48	1507
579-464-1	ST13◇1A-05000D	5000	5173	5100	1046	50	1550
579-465-1	ST13◇1A-05200D	5200	5373	5300	246	52	1609
579-466-1	ST13◇1A-05400D	5400	5573	5500	446	54	1652
579-467-1	ST13◇1A-05600D	5600	5773	5700	646	56	1696
579-468-1	ST13◇1A-05800D	5800	5973	5900	846	58	1739
579-469-1	ST13◇1A-06000D	6000	6173	6100	1046	60	1782
579-470-1	ST13◇1A-06200D	6200	6373	6300	246	62	1841
579-471-1	ST13◇1A-06400D	6400	6573	6500	446	64	1885
579-472-1	ST13◇1A-06600D	6600	6773	6700	646	66	1928
579-473-1	ST13◇1A-06800D	6800	6973	6900	846	68	1971
579-474-1	ST13◇1A-07000D	7000	7173	7100	1046	70	2014
579-475-1	ST13◇1A-07200D	7200	7373	7300	246	72	2074
579-476-1	ST13◇1A-07400D	7400	7573	7500	446	74	2117
579-477-1	ST13◇1A-07600D	7600	7773	7700	646	76	2160
579-478-1	ST13◇1A-07800D	7800	7973	7900	846	78	2203
579-479-1	ST13◇1A-08000D	8000	8173	8100	1046	80	2246
579-480-1	ST13◇1A-08200D	8200	8373	8300	246	82	2306
579-481-1	ST13◇1A-08400D	8400	8573	8500	446	84	2349
579-482-1	ST13◇1A-08600D	8600	8773	8700	646	86	2392
579-483-1	ST13◇1A-08800D	8800	8973	8900	846	88	2435
579-484-1	ST13◇1A-09000D	9000	9173	9100	1046	90	2479

Order No.	Code	Effective length L1 (mm)	Scale length L2 (mm)	Scale length L3 (mm)	Scale holder A L4 (mm)	No. of mounting holes	Mass (g)
579-485-1	ST13◇1A-09200D	9200	9373	9300	246	92	2538
579-486-1	ST13◇1A-09400D	9400	9573	9500	446	94	2581
579-487-1	ST13◇1A-09600D	9600	9773	9700	646	96	2625
579-488-1	ST13◇1A-09800D	9800	9973	9900	846	98	2668
579-489-1	ST13◇1A-10000D	10000	10173	10100	1046	100	2711
579-490-1	ST13◇1A-10200D	10200	10373	10300	246	102	2770
579-491-1	ST13◇1A-10400D	10400	10573	10500	446	104	2814
579-492-1	ST13◇1A-10600D	10600	10773	10700	646	106	2857
579-493-1	ST13◇1A-10800D	10800	10973	10900	846	108	2900
579-494-1	ST13◇1A-11000D	11000	11173	11100	1046	110	2943
579-495-1	ST13◇1A-11200D	11200	11373	11300	246	112	3003
579-496-1	ST13◇1A-11400D	11400	11573	11500	446	114	3046
579-497-1	ST13◇1A-11600D	11600	11773	11700	646	116	3089
579-498-1	ST13◇1A-11800D	11800	11973	11900	846	118	3132
579-499-1	ST13◇1A-12000D	12000	12173	12100	1046	120	3175

## Dimensions

- Resolution: 0.001μm

Order No.	Code	Effective length L1 (mm)	Scale length L2 (mm)	Scale length L3 (mm)	Scale holder A L4 (mm)	No. of mounting holes	Mass (g)
579-440-2	ST13◇2A-01100D	1100	1273	1200	146	11	659
579-441-2	ST13◇2A-01200D	1200	1373	1300	246	12	680
579-442-2	ST13◇2A-01300D	1300	1473	1400	346	13	702
579-443-2	ST13◇2A-01400D	1400	1573	1500	446	14	724
579-444-2	ST13◇2A-01500D	1500	1673	1600	546	15	745
579-445-2	ST13◇2A-01600D	1600	1773	1700	646	16	767
579-446-2	ST13◇2A-01700D	1700	1873	1800	746	17	788
579-447-2	ST13◇2A-01800D	1800	1973	1900	846	18	810
579-448-2	ST13◇2A-02000D	2000	2173	2100	1046	20	853
579-449-2	ST13◇2A-02200D	2200	2373	2300	246	22	913
579-450-2	ST13◇2A-02400D	2400	2573	2500	446	24	956
579-451-2	ST13◇2A-02500D	2500	2673	2600	546	25	977
579-452-2	ST13◇2A-02600D	2600	2773	2700	646	26	999
579-453-2	ST13◇2A-02800D	2800	2973	2900	846	28	1042
579-454-2	ST13◇2A-03000D	3000	3173	3100	1046	30	1085
579-455-2	ST13◇2A-03200D	3200	3373	3300	246	32	1145
579-456-2	ST13◇2A-03400D	3400	3573	3500	446	34	1188
579-457-2	ST13◇2A-03600D	3600	3773	3700	646	36	1231
579-458-2	ST13◇2A-03800D	3800	3973	3900	846	38	1274
579-459-2	ST13◇2A-04000D	4000	4173	4100	1046	40	1318
579-460-2	ST13◇2A-04200D	4200	4373	4300	246	42	1377

□ indicates the interface specification (0,4,5,7,8).  
 ◇ indicates the interface specification (0,4,5,7,8).  
 Effective length of ST1382A is up to 3600mm.

## External View

- Double-end fixation type (Effective length: 10 to 3000mm)

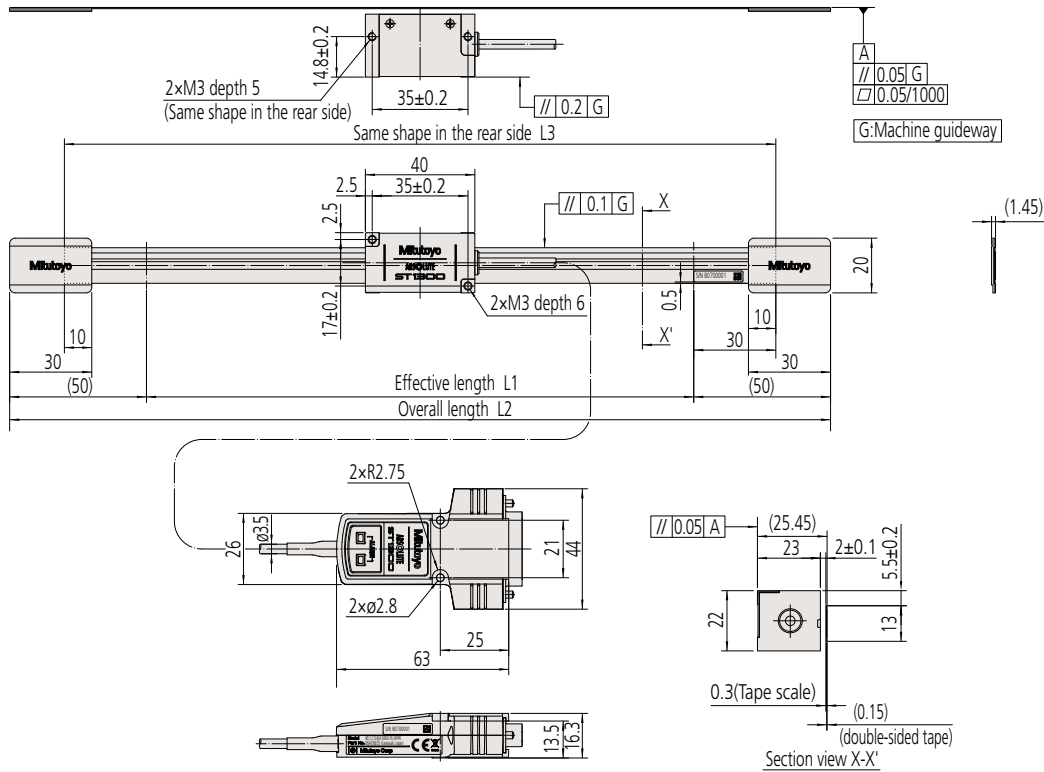

## Dimensions

- Resolution: 0.01µm

Order No.	Code	Effective length L1 (mm)	Scale length L2 (mm)	Scale length L3 (mm)	Mass (g)
579-401-1	ST13◇1A-00010E	10	110	70	300
579-402-1	ST13◇1A-00025E	25	125	85	300
579-403-1	ST13◇1A-00050E	50	150	110	301
579-404-1	ST13◇1A-00075E	75	175	135	302
579-405-1	ST13◇1A-00100E	100	200	160	303
579-406-1	ST13◇1A-00150E	150	250	210	305
579-407-1	ST13◇1A-00200E	200	300	260	307
579-408-1	ST13◇1A-00250E	250	350	310	309
579-409-1	ST13◇1A-00300E	300	400	360	311
579-410-1	ST13◇1A-00350E	350	450	410	313
579-411-1	ST13◇1A-00400E	400	500	460	315
579-412-1	ST13◇1A-00450E	450	550	510	317
579-413-1	ST13◇1A-00500E	500	600	560	319
579-414-1	ST13◇1A-00600E	600	700	660	323
579-415-1	ST13◇1A-00700E	700	800	760	327
579-416-1	ST13◇1A-00800E	800	900	860	331
579-417-1	ST13◇1A-00900E	900	1000	960	335
579-418-1	ST13◇1A-01000E	1000	1100	1060	339
579-419-1	ST13◇1A-01100E	1100	1200	1160	343
579-420-1	ST13◇1A-01200E	1200	1300	1260	346
579-421-1	ST13◇1A-01300E	1300	1400	1360	350
579-422-1	ST13◇1A-01400E	1400	1500	1460	354
579-423-1	ST13◇1A-01500E	1500	1600	1560	358
579-424-1	ST13◇1A-01600E	1600	1700	1660	362
579-425-1	ST13◇1A-01700E	1700	1800	1760	366
579-426-1	ST13◇1A-01800E	1800	1900	1860	370
579-427-1	ST13◇1A-02000E	2000	2200	2060	378
579-428-1	ST13◇1A-02200E	2200	2400	2260	386
579-429-1	ST13◇1A-02400E	2400	2500	2460	394
579-430-1	ST13◇1A-02500E	2500	2600	2560	398
579-431-1	ST13◇1A-02600E	2600	2800	2660	402
579-432-1	ST13◇1A-02800E	2800	3000	2860	409
579-433-1	ST13◇1A-03000E	3000	3100	3060	417

## Dimensions









- Resolution: 0.001µm

Order No.	Code	Effective length L1 (mm)	Scale length L2 (mm)	Scale length L3 (mm)	Mass (g)
579-401-2	ST13◇2A-00010E	10	110	70	300
579-402-2	ST13◇2A-00025E	25	125	85	300
579-403-2	ST13◇2A-00050E	50	150	110	301
579-404-2	ST13◇2A-00075E	75	175	135	302
579-405-2	ST13◇2A-00100E	100	200	160	303
579-406-2	ST13◇2A-00150E	150	250	210	305
579-407-2	ST13◇2A-00200E	200	300	260	307
579-408-2	ST13◇2A-00250E	250	350	310	309
579-409-2	ST13◇2A-00300E	300	400	360	311
579-410-2	ST13◇2A-00350E	350	450	410	313
579-411-2	ST13◇2A-00400E	400	500	460	315
579-412-2	ST13◇2A-00450E	450	550	510	317
579-413-2	ST13◇2A-00500E	500	600	560	319
579-414-2	ST13◇2A-00600E	600	700	660	323
579-415-2	ST13◇2A-00700E	700	800	760	327
579-416-2	ST13◇2A-00800E	800	900	860	331
579-417-2	ST13◇2A-00900E	900	1000	960	335
579-418-2	ST13◇2A-01000E	1000	1100	1060	339
579-419-2	ST13◇2A-01100E	1100	1200	1160	343
579-420-2	ST13◇2A-01200E	1200	1300	1260	346
579-421-2	ST13◇2A-01300E	1300	1400	1360	350
579-422-2	ST13◇2A-01400E	1400	1500	1460	354
579-423-2	ST13◇2A-01500E	1500	1600	1560	358
579-424-2	ST13◇2A-01600E	1600	1700	1660	362
579-425-2	ST13◇2A-01700E	1700	1800	1760	366
579-426-2	ST13◇2A-01800E	1800	1900	1860	370
579-427-2	ST13◇2A-02000E	2000	2100	2060	378
579-428-2	ST13◇2A-02200E	2200	2400	2260	386
579-429-2	ST13◇2A-02400E	2400	2500	2460	394
579-430-2	ST13◇2A-02500E	2500	2600	2560	398
579-431-2	ST13◇2A-02600E	2600	2800	2660	402
579-432-2	ST13◇2A-02800E	2800	3000	2860	409
579-433-2	ST13◇2A-03000E	3000	3100	3060	417

□ indicates the interface specification (0,4,5,7,8).  
◇ indicates the interface specification (0,4,5,7,8).

## ABS ST1300 Signal Verification Program

- When the ST1300 signal verification program has been installed in a PC, the program allows signal verification and maintenance work of the scale by connecting the conversion unit and the PC to the ABS ST1300 series. (The signal verification work is indispensable. For details, refer to the User's Manual.)
- Description of signal verification program

Item	Description	Screen photo
(1) Verification of the detector head mounting position relation	Allows check and judgment of the mounting status by acquiring data from the tape scale.	
(2) Verification of the total length of tape scale	Allows check and judgment of the mounting status by acquiring data of the total length of the tape scale.	
(3) Setting the scale origin	Allows the scale origin (positional data: 0) to be set at an arbitrary point of the scale.	
(4) Verification of the absolute position data	Allows verification of the current position data with reference to the scale origin, and the alarm code and alarm information outputted while being attached to the position data.	
(5) Clearing error records	Allows records of error detection in the scale to be cleared.	
(6) Writing system parameters	Allows system parameters to be written in the detector head.	
(7) Reading system parameters	Allows system parameters stored in the detector head to be read out and displayed.	
(8) Reading and storing error records	Allows readout of a detailed internal error code, verification of error code information and saving error codes as an error record file in the PC.	
(9) Signal monitor	Allows check of the acquired data over the total length of the tape scale.	

### • Connection Method

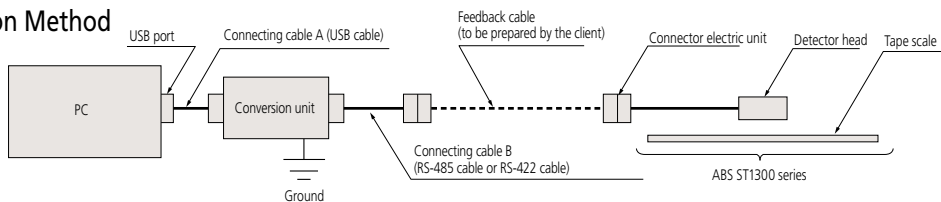

\* To prevent an electric shock, properly ground the system.

### • Order No. of "conversion unit and signal verification program" set

Order No.	Conversion unit + Accessories (*1)	Connecting cable B
06AEX139	Signal verification program Conversion unit USB-485 DS15P	MEL-J3 cable (Mitsubishi Electric Corporation)
06AEX140	Conversion unit manual Device driver (CD-ROM)	Y/MAT cable (YASUKAWA Electric Corporation)
06AFA406	Conversion unit USB device Installation manual	MIT cable (Nikki Denso)
06AFA407	Connecting cable A (USB cable) Connecting cable B	FANUC cable

\* Order No. is applied to each company's I/F because connecting cable B differs depending on the I/F of ABS ST1300 series.

# ABS AT1100 Series

(Resolution 0.05μm Specification)



## Features

- This series has adopted a new structure not easily subject to infiltration of coolant and dust-proof rubber highly resistant to coolant. It offers a field support type linear scale with higher reliability than before.
- The sensor-to-scale air gap is approx. 0.4mm, around 4 times as wide as that of the conventional optical or electromagnetic sensor. This has made trouble due to a bite of foreign bodies, etc. unlikely to occur. This sensor-to-scale air gap is the world's largest class as a machine tool-oriented scale.
- The de facto standard frame multipoint mounting method has been adopted, thus achieving high resistance to vibration and shock.
- A newly-developed small sensor is installed on the scale unit of Mitutoyo-unique electromagnetic induction method.
- The improvement of signal processing technology in the electromagnetic induction type absolute linear encoder has achieved approximately 6 times higher accuracy than that of our predecessors.
- This series is compatible with the high-speed serial interlace of each company, allowing direct connection to an NC controller.

## Meaning of Model No.

**ABS AT11□3** - □□□□  
Effective length

Interface specifications

Applicable system	Scale model
FANUC Ltd., Serial α i interface	<b>ABS AT1153</b>
Mitsubishi Electric Corporation, High speed serial interface	<b>ABS AT1143</b>
Siemens AG, DRIVE-CLiQ	<b>ABS AT1123</b>

\* For the details of applicable system, inquire with each manufacture.

## Scale configuration

[ABS AT1100 Series]

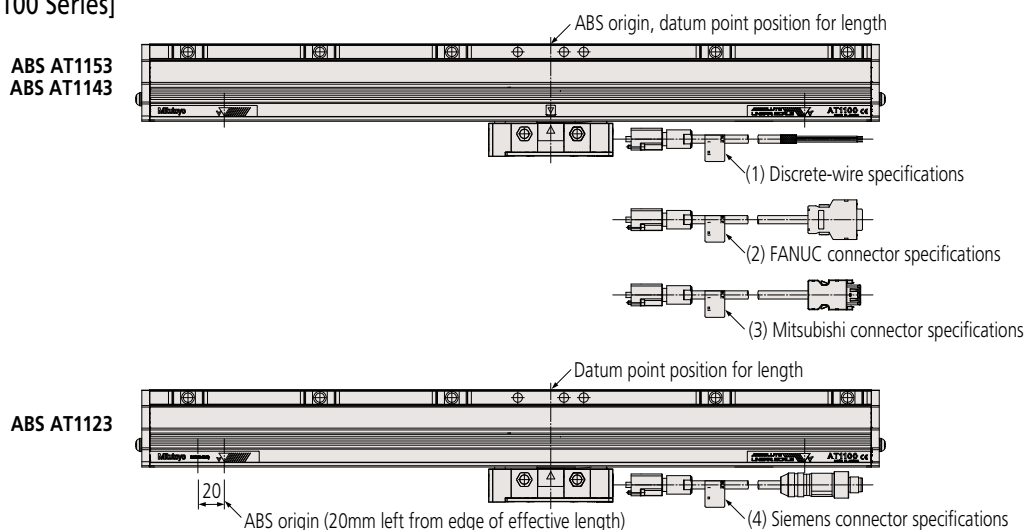

## Specifications

Items	Model	ABS AT11□3
Detection method		Electromagnetic induction
Scale unit mounting method		Frame multipoint mounting method
Reference position to extension due to temperature variation		Refer to the External View (L5)
Detection method	24 types: 140,240,340,440,540,640,740,840,940,1040,1140,1240,1340,1440,1540,1640,1740,1840,2040,2240,2440,2640,2840,3040	
Resolution		0.05μm
Maximum response speed		3m/sec
Indication accuracy (20°C)		Effective length $L_0=140-2040\text{mm}$ : $3+5L_0/1000$ (μm) Effective length $L_0=2240-3040\text{mm}$ : $5+5L_0/1000$ (μm)
Expansion coefficient		$\approx 8 \times 10^{-6} / \text{K}$
Vibration resistance		$\leq 196\text{m/s}^2$ (20G) (55 - 2000Hz)
Shock resistance		Effective length $L_0=140-2040\text{mm}$ : $\leq 343\text{m/s}^2$ (35G) Effective length $L_0=2240-3040\text{mm}$ : $\leq 294\text{m/s}^2$ (30G) (1/2sin 11ms)
Power supply voltage		ABS AT1153/1143: DC5V±10% ABS AT1123: DC24V (Conformed to DRIVE-CLiQ)
Maximum consumption current		AT1153: 300mA (Max) AT1143: 290mA (Max) AT1123: 140mA (Max)
Operational temperature/ humidity range		0 - 50°C 20 - 80%RH (non-condensing)
Storage temperature/ humidity range		-20 - 70°C 20 - 80%RH (non-condensing)

## System Configuration (Example)

### [ABS AT1153/AT1143]

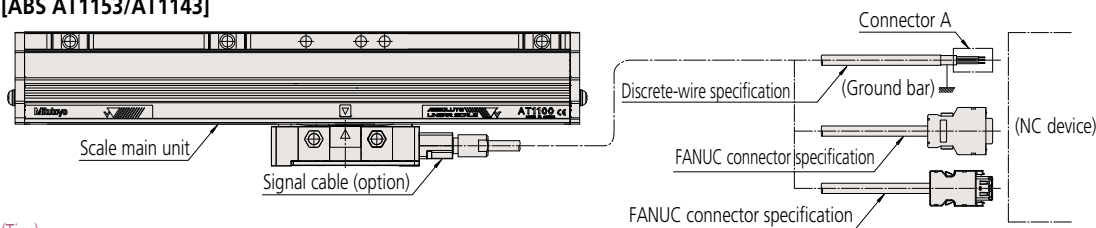

#### (Tips)

1. The signal cable is an option. Prepare one according to your needs.
2. Prepare connector A yourself.
3. Conduct connection work of connector A and ground bar yourself.

### [ABS AT1123]

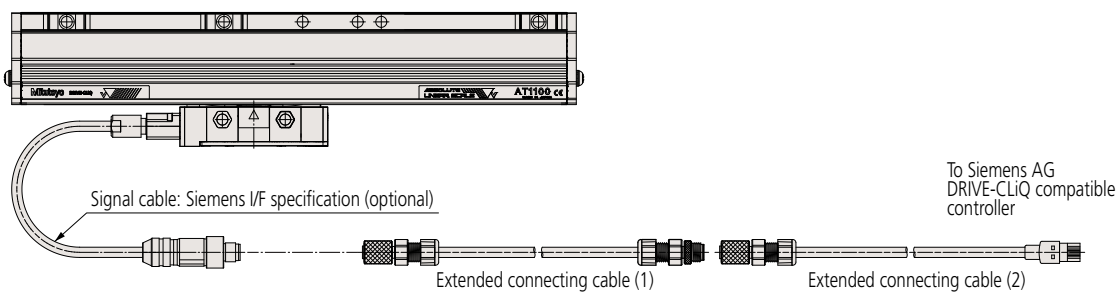

\* The extended connecting cable (1) and (2) should be prepared by the client.

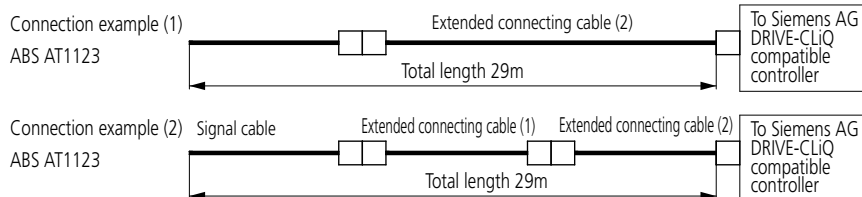

- Extended connecting cable (1) SIEMENS AG Model No. 6FX8002-2DC34 - □ □ □ □
- Extended connecting cable (2) SIEMENS AG Model No. 6FX8002-2DC30 - □ □ □ □

#### (NOTE)

1. The extended connecting cable(s) should be prepared by the client.
2. Keep the total length of signal cable and extended connecting cable(s) less than 29m.
3. For the signal cable specification and how to obtain, contact Siemens AG.



## Output specifications

### • ABS AT1153/1143 (discrete-wire)

Wire color	Signal
Brown	SD
Red	*SD
Orange	RQ (REQ)
Yellow	*RQ (REQ)
White (2P)	+5V
Black (2P)	GND
Shield wire	F.G

\* Prepare cable at cable yourself (A total of 29 meters with the signal cable).

### • ABS AT1153

FANUC connector specifications (FI-20)

Pin No.	Signal
1	SD
2	*SD
5	RQ(REQ)
6	*RQ(REQ)
12.14	GND
18.20	+5V
16	F.G
3.4.7. - 13.15.17.19	Not used

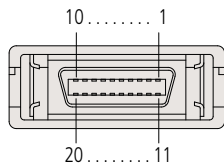

### • ABS AT1143

Mitsubishi connector specifications (MDR)

Pin No.	Signal
1	5V
2	GND
3	RQDT
4	RQDT
7	DT
8	DT
5.6.9.10	Not used
Connector shell	F.G

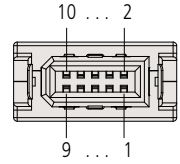

### • ABS AT1123

M12 connector specifications

Pin No.	Signal
1	+24V
2	TEST
3	RXP
4	RXN
5	GND
6	TXN
7	TXP
8	TEST
Shield sleeve	F.G

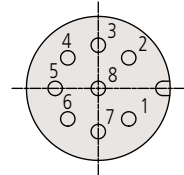

Note: Leave test terminals (Pin No.9 and 10) disconnected during use.

## Cable Dimensions

Unit: mm

- **ABS AT1153/1143 (discrete-wire specification)**

Detector head (custom) side: Waterproof

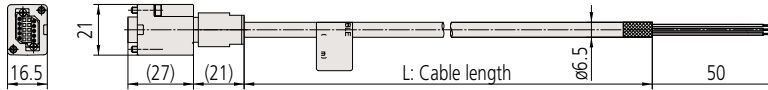

Code No.	Model	Cable length (m)
<b>06AFG596-1</b>	AT1100F/M discrete-wire cable 1m	1
<b>06AFG596-3</b>	AT1100F/M discrete-wire cable 3m	3
<b>06AFG596-6</b>	AT1100F/M discrete-wire cable 6m	6
<b>06AFG596-9</b>	AT1100F/M discrete-wire cable 9m	9
<b>06AFG596-12</b>	AT1100F/M discrete-wire cable 12m	12

\* Discrete-wire cable can not be used for ABS AT1123 (SIEMENS I/F).

- **ABS AT1153 (FANUC connector specifications)**

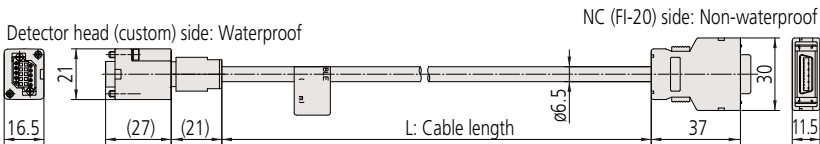

Code No.	Model	Cable length (m)
<b>06AFF921-1</b>	AT1100F Cable FUNUC 1m	1
<b>06AFF921-3</b>	AT1100F Cable FUNUC 3m	3
<b>06AFF921-6</b>	AT1100F Cable FUNUC 6m	6
<b>06AFF921-9</b>	AT1100F Cable FUNUC 9m	9

- **ABS AT1143 (Mitsubishi connector specifications)**

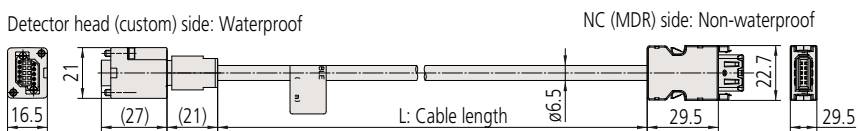

Code No.	Model	Cable length (m)
<b>06AFF957-1</b>	AT1100M Cable MDS-D 1m	1
<b>06AFF957-3</b>	AT1100M Cable MDS-D 3m	3
<b>06AFF957-6</b>	AT1100M Cable MDS-D 3m	6
<b>06AFF957-9</b>	AT1100M Cable MDS-D 9m	9

- **ABS AT1123 (M12 connector specifications)**

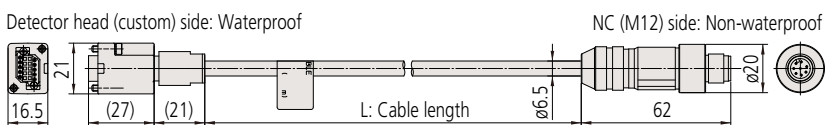

Code No.	Model	Cable length (m)
<b>06AFL121-1</b>	AT1100S Cable M12 1m	1
<b>06AFL121-3</b>	AT1100S Cable M12 3m	3
<b>06AFL121-6</b>	AT1100S Cable M12 6m	6
<b>06AFL121-9</b>	AT1100S Cable M12 9m	9

## External View

### • ABS AT1153/AT1143

Unit: mm

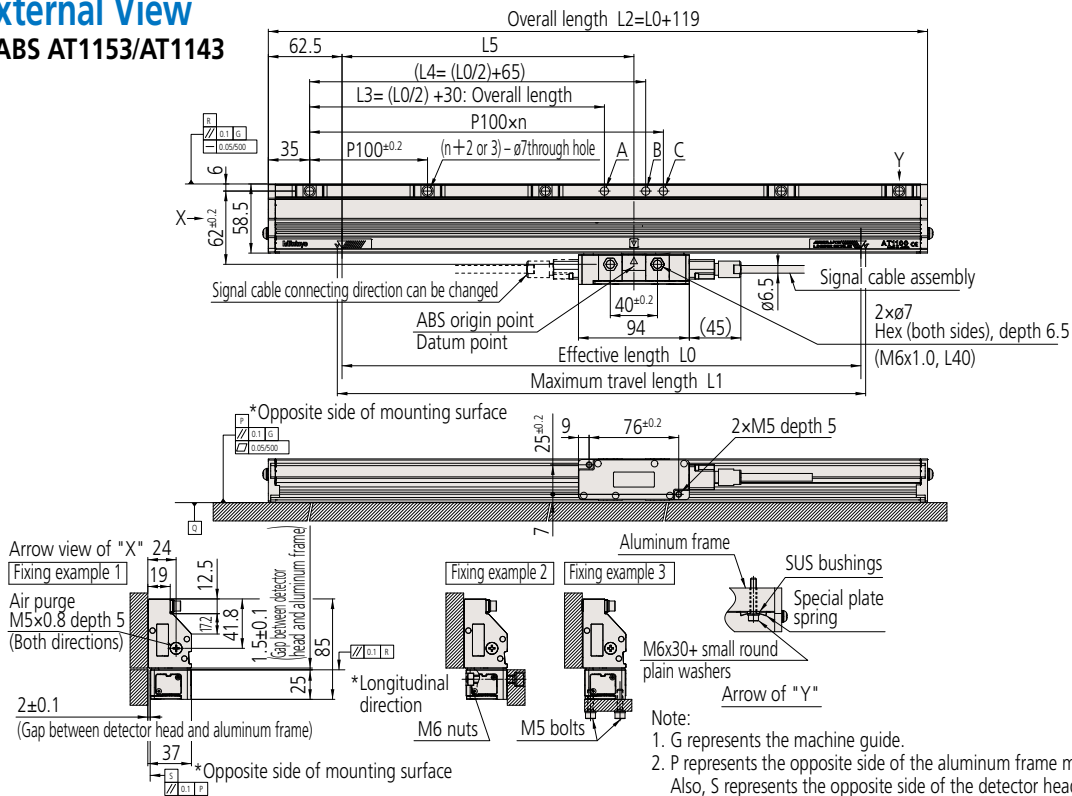

## Dimensions

Order No.	Model	Effective length	Maximum travel length	Overall length	Mounting pitch		No. of mounting holes	
		L0 (mm)	L1 (mm)	L2 (mm)	L3 (mm)	L5 (mm)		
559-100-□3	AT11□3-140	140	148	259	100	135	90	2
559-101-□3	AT11□3-240	240	248	359	150	185	147.5	3
559-102-□3	AT11□3-340	340	348	459	200	235	190	4
559-103-□3	AT11□3-440	440	448	559	250	285	247.5	5
559-104-□3	AT11□3-540	540	548	659	300	335	290	6
559-105-□3	AT11□3-640	640	648	759	350	385	347.5	7
559-106-□3	AT11□3-740	740	748	859	400	435	390	8
559-107-□3	AT11□3-840	840	848	959	450	485	447.5	9
559-108-□3	AT11□3-940	940	948	1059	500	535	490	10
559-109-□3	AT11□3-1040	1040	1048	1159	550	585	547.5	11
559-110-□3	AT11□3-1140	1140	1148	1259	600	635	590	12
559-111-□3	AT11□3-1240	1240	1248	1359	650	685	647.5	13
559-112-□3	AT11□3-1340	1340	1348	1459	700	735	690	14
559-113-□3	AT11□3-1440	1440	1448	1559	750	785	747.5	15
559-114-□3	AT11□3-1540	1540	1548	1659	800	835	790	16
559-115-□3	AT11□3-1640	1640	1648	1759	850	885	847.5	17
559-116-□3	AT11□3-1740	1740	1748	1859	900	935	890	18
559-117-□3	AT11□3-1840	1840	1848	1959	950	985	947.5	19
559-118-□3	AT11□3-2040	2040	2048	2159	1050	1085	1047.5	21
559-119-□3	AT11□3-2240	2240	2248	2359	1150	1185	1147.5	23
559-120-□3	AT11□3-2440	2440	2448	2559	1250	1285	1247.5	25
559-121-□3	AT11□3-2640	2640	2648	2759	1350	1385	1347.5	27
559-122-□3	AT11□3-2840	2840	2848	2959	1450	1485	1447.5	29
559-123-□3	AT11□3-3040	3040	3048	3159	1550	1585	1547.5	31

\* □ in Order No. and Model indicates the interface specification as follows:  
 AT1143: 4  
 AT1153: 5

## External View

### • ABS AT1123

Unit: mm

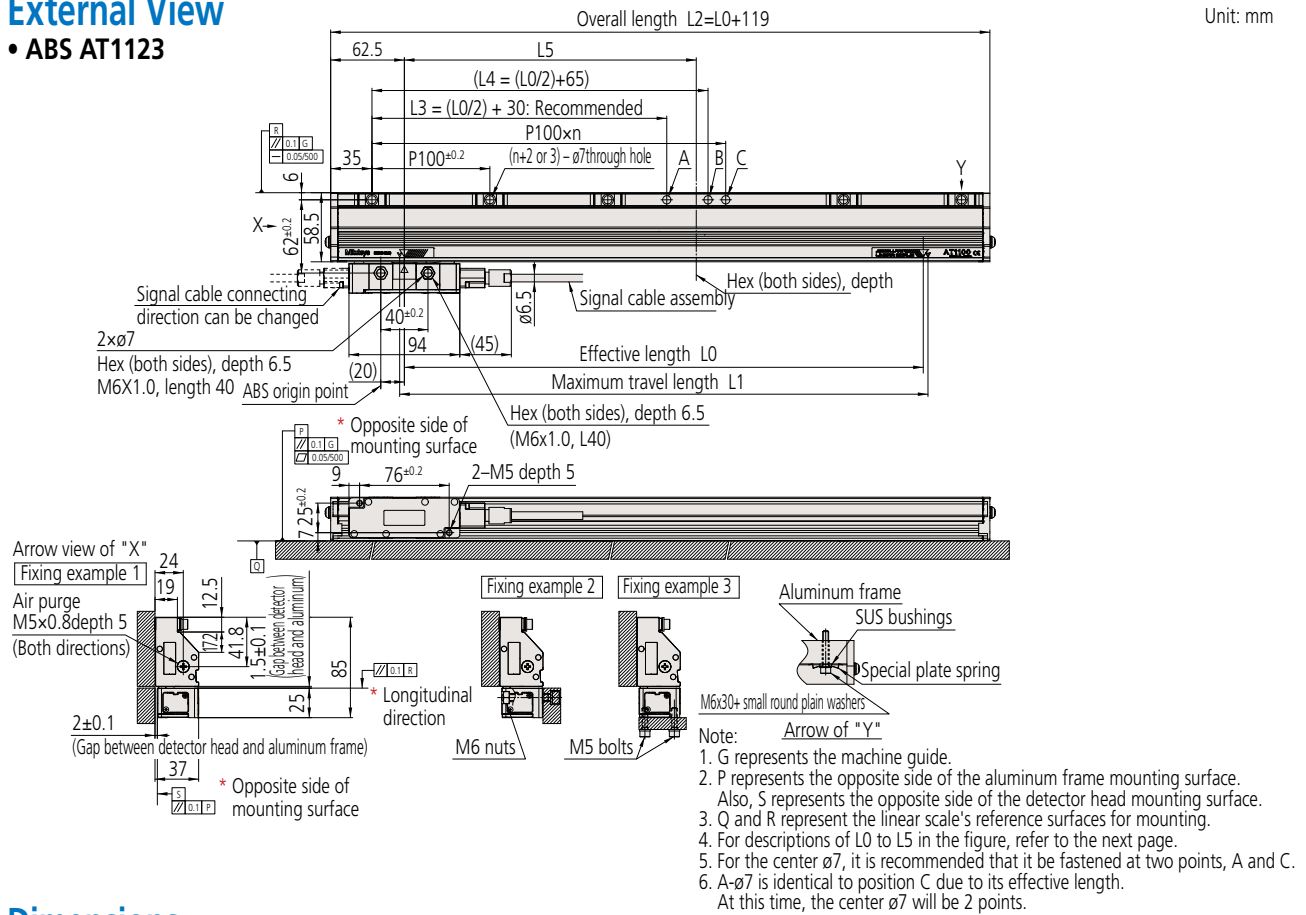

## Dimensions

Order No.	Model	Effective length	Maximum travel length	Overall length	Mounting pitch			No. of mounting holes
		L0 (mm)	L1 (mm)		L3 (mm)	L4 (mm)	L5 (mm)	
559-100-23	AT1123-140	140	148	259	100	135	90	2
559-101-23	AT1123-240	240	248	359	150	185	147.5	3
559-102-23	AT1123-340	340	348	459	200	235	190	4
559-103-23	AT1123-440	440	448	559	250	285	247.5	5
559-104-23	AT1123-540	540	548	659	300	335	290	6
559-105-23	AT1123-640	640	648	759	350	385	347.5	7
559-106-23	AT1123-740	740	748	859	400	435	390	8
559-107-23	AT1123-840	840	848	959	450	485	447.5	9
559-108-23	AT1123-940	940	948	1059	500	535	490	10
559-109-23	AT1123-1040	1040	1048	1159	550	585	547.5	11
559-110-23	AT1123-1140	1140	1148	1259	600	635	590	12
559-111-23	AT1123-1240	1240	1248	1359	650	685	647.5	13
559-112-23	AT1123-1340	1340	1348	1459	700	735	690	14
559-113-23	AT1123-1440	1440	1448	1559	750	785	747.5	15
559-114-23	AT1123-1540	1540	1548	1659	800	835	790	16
559-115-23	AT1123-1640	1640	1648	1759	850	885	847.5	17
559-116-23	AT1123-1740	1740	1748	1859	900	935	890	18
559-117-23	AT1123-1840	1840	1848	1959	950	985	947.5	19
559-118-23	AT1123-2040	2040	2048	2159	1050	1085	1047.5	21
559-119-23	AT1123-2240	2240	2248	2359	1150	1185	1147.5	23
559-120-23	AT1123-2440	2440	2448	2559	1250	1285	1247.5	25
559-121-23	AT1123-2640	2640	2648	2759	1350	1385	1347.5	27
559-122-23	AT1123-2840	2840	2848	2959	1450	1485	1447.5	29
559-123-23	AT1123-3040	3040	3048	3159	1550	1585	1547.5	31